

# MODULAR ISDN DATA ACCESS SOLUTION

M

I

D

A

S

ULC

## DISTINCTIVE CHARACTERISTICS

- ◆ Smart BRI ISDN Data Card
  - Internal ISA card version
  - External standalone version
- ◆ Dual Analog POTS Circuit
- ◆ ISDN Call Setup available for North America
- ◆ Total Advanced Prototype Solution
  - Q.931 + Q.921 + Chip Drivers
  - Complete Design Package with 2 cards
- ◆ Available Windows 95 Drivers and APIs
  - NDIS WAN Miniport
  - VCOMM.vxd with AT PAD
  - WinISDN
  - TeleSoft API
- ◆ Integral 2-wire NT-1
- ◆ Call Control/Data Transfer Interfaces
  - Dual-Port RAM or PC UART COM (internal card)
  - RS232/V.24 (external card)
- ◆ Ideal for TAs, Digital Modems, Routers, Internet Access and LAN Remote Access
- ◆ Enables High-Margin/Low-Cost Products
- ◆ Minimizes Technology Risks
- ◆ Cuts Time-to-Market by 60% or more



## TECHNOLOGY TRANSFER FOR OEMs

designed specifically to meet the needs of OEMs and ODMs for fast development of low-cost ISDN products.

Each MIDAS product is a Technology Transfer Package that gives you full control over your product design and direction. You can customize to differentiate, add value or change form factor. You have full flexibility for your first and future products

because MIDAS includes a complete Hardware Design Kit and Software Source Code Kit. You get schematics, Gerber files, board layout and component listings, and fully functioning cards loaded with object code.

MIDAS-ULC is available in several standard Product Configuration versions; please refer to the Product Configuration table on the back of this sheet for details.

# TeleSoft

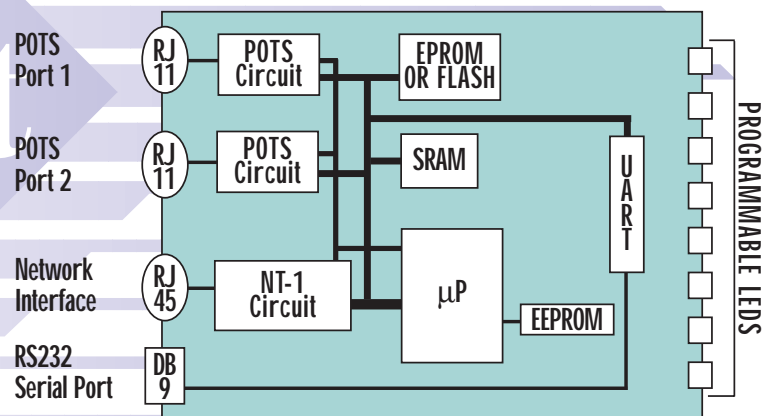

MIDAS-ULC Functional Block Diagram  
(Example of external product)

## MIDAS-ULC, Active BRI Specification

Types	External and Internal Cards
Network Protocols Supported	US NI-1 + 5ESS + DMS100
Network Connection	2-Wire "U" via RJ45—conformant to ANSI T1.601
Serial Port (external card)	RS232/V.24 via 9-pin D connector
Serial Port (internal card)	PC UART 16C650
Async Speeds (V.120)	300—115,200 bps (V.120 + Async-Sync ML-PPP)
Async Data Format	7-bit data + odd/even parity; 8-bit no parity
Processor	MC68302—20 MHz
RAM	Standard: 128 KBytes; Optional 512 KBytes
FLASH/EPROM	Standard: 256 KBytes; Optional 512 K or 1024 KBytes
Data Connections supported	1 or 2 B-Channels (Async-Sync ML-PPP) 1 B-Channel (V.120)
B-Channel Protocols supported	V.120; Async-Sync ML-PPP; X.25
Dialing Interface	Modem AT Commands via Serial Port
Analog POTS Port (2)	Auto Answer with Ringing & DTMF Detection via RJ11
Serial TTL Interface	Async V.120 + Async-Sync ML-PPP via MC68302 SCC/UART
Serial TTL Interface (DCE)	V.120 service: TxD, RxD, RTS, CTS, DCD, DTR, RxC, TxC
ISA Bus Interface (internal card)	Dual-port RAM 4 KBytes, selectable base address 68302-to-Host selectable IRQ3, 5, 9, 10 Host-to-68302 interrupt Software Reset by Host PC-COM port selectable for COM1—COM4
LEDs (external card)	Eight, Software programmable
Dimensions: H x W x D	20 x 185 x 135 mm. (0.8 x 7.25 x 5.25 in.)
Power	+ 9 Vdc (external card) + 5 Vdc, +12Vdc (internal card)

## MIDAS-ULC BRI Product Configurations

Product Description	APIs & Drivers					B-Channel Protocols			
	Host Interface AT PAD COM	Port NDIS WAN Miniport	WinISDN AT PAD VCOMM	V.120 V.110 Async-Sync ML-PPP	Raw HDLC				
Digital Modem	Async COM	◆				◆	◆	◆	
NDIS WAN	DP RAM		a						◆
WinISDN	DP RAM			b					◆
VCOMM	DP RAM				a	◆		◆	
Clear Channel	DP RAM								

*a = operates under Win 95 only; b = operates under Win 95 and Win 3.1x*

Each of the Product Configurations listed is pre-tested on the MIDAS platform and delivered as Source and Object Code loads. The MIDAS products are advanced prototypes that allow customizing and require productizing before release to production.



**Intelligent  
ISDN Solutions**

### Marketing and Design Center

4029 South Capital of Texas Hwy.  
Suite 220  
Austin, TX 78704

Tel: 512.373.4224

Fax: 512.447.1024

Website: <http://www.telesoft-intl.com>

E-mail: [sales@telesoft-intl.com](mailto:sales@telesoft-intl.com)